



## **USER MANUAL – IKOTEC 3000**

The Ikotec 3000 with a single column is designed for lifting a vehicle sideways to allow for mechanical repair, bodywork or repainting. It consists of a compact system with a single movable column with different attachments for various types of work, with a lifting capacity of vehicles up to 5000 Lbs.

Basic environmental conditions are temperatures from 14 °F to 95 °F, maximum humidity of 80%. Do not use in damp conditions, standing water, rain or snow. Use only on a flat level surface. Use the shortest approved heavy extension cord if needed. Always use the stand provided or an approved substitute. Failure to follow these procedures can lead to injury or death.

### **TECHNICAL DESCRIPTION**

- A. The system consists of a single column, electrical components to be connected only to the user's power outlet.**
- B. Electrical Components**
1. A motor of 1.5hp at 1725 rpm for 110 V (high starting torque) or 1.5hp at 1725 rpm for 220 V.
  2. Reversing switch of three poles with a bridge for single-phase installation of 32 amps with return-to-zero.
  3. Connecting cables:
    - a. Power feeding cable RV-K 3 x 1,5 mm (2 m long)
    - b. Connection switch-motor with the cable RV-K 4 x 1 mm (0,80 m long)
  4. Connectors AT 1,5/4 for the motor and AT 1,5/5 for ground
  5. Clamps 140 x 3,6
- C. Attachments – The Components used with this unit to accomplish a variety of uses**
1. **3000-1 Lifting Fork:** A holding device for wheels. Safely and quickly lift almost any vehicle by the tire front or rear.
  2. **3000-2 Sill Support:** Accessory to lift from the sill or pinch weld. Lift most small vehicles quickly allowing both wheels on the same side to be free.
  3. **3000-2a Plane Plate Sill Support Adapter:** Plane adapter to use with sill support stand.
  4. **3000-3 Tuning Sill Support (Sport Cars):** Safely lift vehicles that are low to the ground from the sill support (pinch weld)
  5. **3000-4 Transmission Adapter Head & Push:** This adapter quickly attaches to the lift to aid in transmission, fuel tank, transfer cage and any other removal & installation."
  6. **3000-5 Shop Crane Adapter Head:** Accessory to be used as an engine or general lift. Weight limit: 750lbs - Leg extensions included.
  7. **3000-6 Jack Stand:** Accessory to be used to support vehicle after lifting and before any work is performed.
  8. **3000-7 Total Sill Support:** Accessory to lift like the sill support on 2 points. Great attachment for the shops to lift most vehicles from the side allowing both wheels on the same side to be free.
  9. **3000-10 Spring Compressor:** Accessory to press springs and replace stock or Macpherson strut cartridges.
  10. **3000-11 Quick Fit Plate:** Used to lift the vehicle from the side leaving the wheels free for removal tire rotation, replacement, brake inspection and more."
  11. **3000-12 Door Support A:** Used for working on automobile doors off of the vehicle in just about any position and height.
  12. **3000-12b Door Support B:** Used for removing or replacing vehicle doors, also for repairing door hinges.
  13. **3000-13 Hitch Adapter:** Design to lift a vehicle by the hitch. It may also be used to install a new hitch onto a vehicle that currently does not have one.
  14. **3000-14 Wheel Sled:** Used to safely lift on grated floors, such as in down draft spray booths.
  15. **3000-15 Engine Stand:** Engine stand for cars and light truck motors, which gives the user the flexibility to adjust the height and position.
  16. **3000-16 Motorcycle Attachment:** Safely lift almost any motorcycle with both wheels free. This also gives the user the added ability to use up to 4 safety straps.
  17. **3000-17 Rollout:** Wheel Chock device prevents hoses and cords from becoming entangled between the vehicle and the ground.
  18. **3000-18 Transport:** Multipurpose shop transport dolly. This device provides free wheel movement of a vehicle. This means you can move your vehicle in your shop with or without the wheels attached. This device may also be used to place a vehicle on a frame machine.
  19. **3000-19 Leg Extensions:** Provide additional load balancing for your Ikotec lifts by attaching leg extensions.



**D. The Ikotec 3000 consists of:**

1. *The Column* - The basic part of the system consists of a specially shaped column of folded metal sheet into which the lifting carriage is placed. It contains two channels for the control system, a horizontal bar as a grip for moving the machine, motor mounting, belt tightening screw and the top cover with a housing for the conical load bearing.
2. *The Base* - The base is A-shaped with fixed wheels at two of its ends and a mobile one at the third opposite end. This ensures stability and mobility. The base is made of two parallel bars bent at the right angle, a beam soldered to the parallel bars and two centered holes. The bottom of the bars has housing for a ball bearing.
3. *Lifting Carriage* - The carriage consists of a U-shaped structure, with two axles containing each a wheel with dry bushings, which carry the weight to lift, a cover with a hole for the spindle, and a vertical hook at the front for holding the different fittings. Inside is a force nut of an appropriate material for this function. Also a safety nut with an appropriate mechanism to stop the use in case of wears out from the principal nut.
4. *Control Mechanism* - The control mechanism consists of parallel bars in a special design, on the top of which there is a control lever for the lifting and lowering of the vehicle. A reversing switch is attached to the bottom part of the bars, for the forward and backward run of the motor. This switch has its own box, with power cables going to the electrical motor on one side and to the electrical outlet on the other. The electrical motor's power is of 1.5hp 1727rpm, single-phase with high starting torque. The bars have two limit stops which mark the travel end for a total of approx. 1 m between the two ends. The bar also contains a pin for the safety control system.
5. *Power Mechanism* - Parallel to the column is a spindle which, through rotation, lifts or lowers the weight. It is supported between the upper and the lower bearings. Underneath, a pulley is linked through a belt with a motor pulley, located above the axle of the electrical motor.

**SPECIFICATIONS**

**Sizes:**

- A. Total height: 1340 mm
- B. Footprint: 900 x 75 mm
- C. Weight: 82 kg
- D. Lifting capacity PTT : 5000lbs
- E. Max. lifting height: approximately 1m
- F. Max. lifting time: 35s
- G. Max. wheel size: 20"
- H. Electrical protection: IP 40
- I. Contact protection: grounded
- J. Electrical motor: guaranteed against voltage fluctuation up to  $\pm 5\%$  and frequency fluctuation up to  $\pm 1\%$

**MAINTENANCE**

- Grease center screw monthly
- Check bolt periodically for wear

**NOTICE AND WARNINGS**

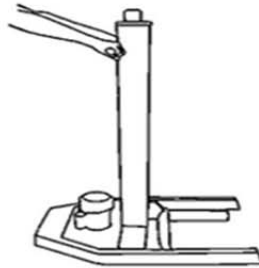
- A. MAKE SURE YOU FOLLOW THE MANUFACTURERS RECOMMENDATION FOR LIFTING A VEHICLE WITH AIR SUSPENSION.
- B. DO NOT USE THIS LIFT ON HIGH TOP OR CONVERSION VANS.
- C. ALWAYS USE A HITCH PIN WHEN USING THE TRAILER HITCH ADAPTER
- D. **ALWAYS RELEASE THE HANDBRAKE AND PLACE TRANSMISSION IN NEUTRAL**

***OPERATING YOUR IKOTEC 3000 OUTSIDE OF THE RECOMMENDED MANUFACTURER'S INSTRUCTIONS, GUIDELINES, AND NOTICES WILL VOID YOUR DEVICE WARRANTY***



**USAGE INSTRUCTIONS – IKOTEC 3000**

1. Move the Lift with the handlebar. (see figure 1)



**Figure 1**

2. Put in the desired position, i.e. at the front or rear wheel of the vehicle which you want to lift, with the holding device for wheels (Push until it touches the tire) or the holding device for the sill.

3. Plug the lift into the outlet. (see figure 2)



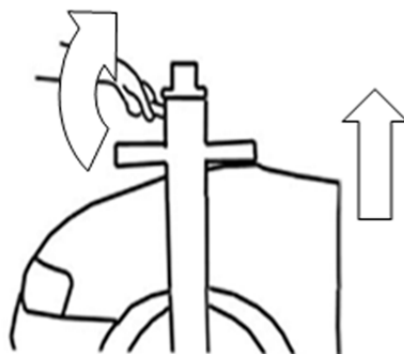
**Figure 2**

4. Before lifting the vehicle, make sure the engine is turned off. **Loosen the handbrake and put the transmission in neutral** (see figure 3)

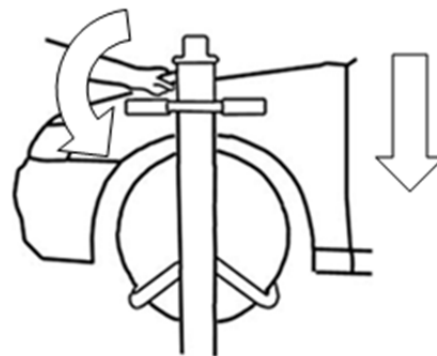


**Figure 3**

5. Once these steps are completed, the vehicle can be lifted, as shown in the following image, moving up the lever until the desired height of the vehicle is reached (see figure 4) and moving down for lowering the vehicle. Don't forget to **loosen the handbrake and put the transmission in neutral when you are using the IKOTEC 3000**. In event you have no power available and the vehicle is in a lifted state, you can lower the vehicle by removing the top rubber cap and turning the spindle anticlockwise with a 30 mm wrench.



**Figure 4**

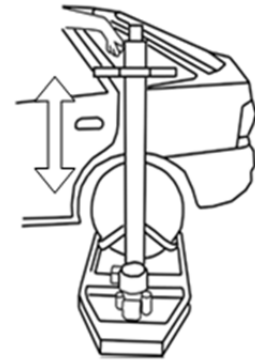


**Figure 5**

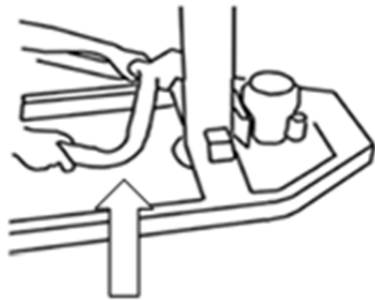
6. You can also lift the vehicle at the rear wheel by proceeding as explained above. (see figure 6)

7. In case you want to lift the vehicle by the sill instead of by a wheel, you will have to replace the holding device for the wheel by the holding device for the sill. To do this, follow the next steps: **Don't forget to loosen the handbrake of the vehicle and to put the transmission in neutral!!!**

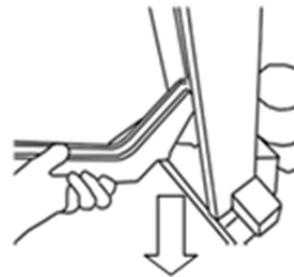
- a. Lift the holding device for the wheel, then take it from the groove and place the holding device for the sill in it as shown in figure 8



**Figure 6**



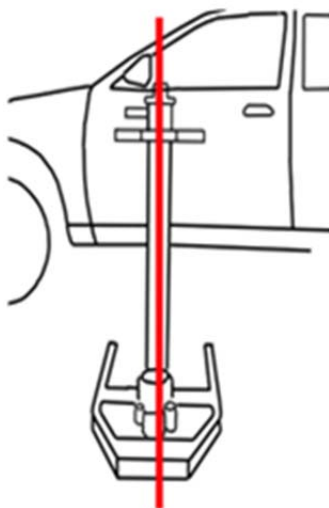
**Figure 7**



**Figure 8**

8. Once the holding device for the sill is placed in the IKOTEC 3000 the vehicle can be lifted sideways, following the next steps:

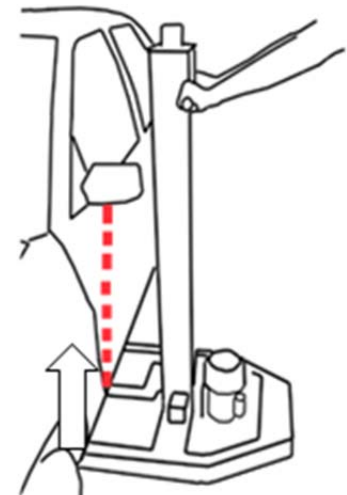
Place the lift perpendicular to the vehicle's side-view mirror as shown in figures 8, 9, 10



**Figure 8**



**Figure 9**



**Figure 10**

9. Remember that the Ikotec 3000 with the holding device for the sill always has to be aligned with the vehicle's external rear-view mirror. Never in the center (see figure 11) or at the back (see figure 12).

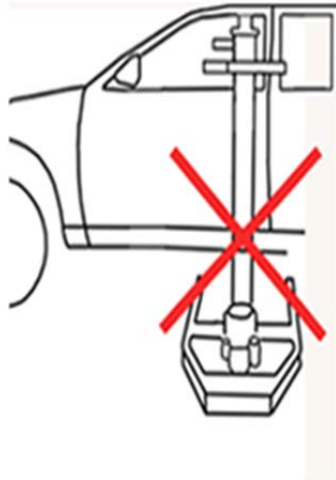
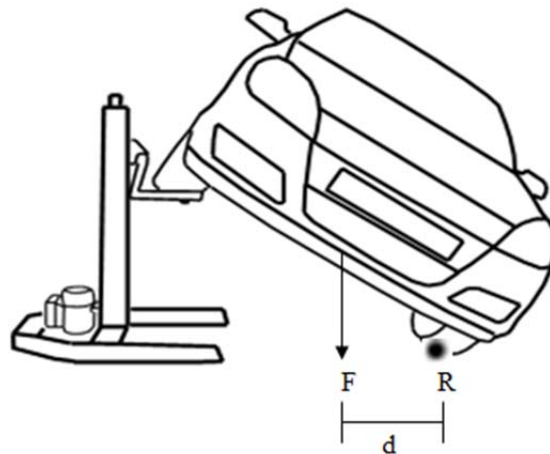


Figure 11



Figure 12

Why does the vehicle not turn over when lifting it with the Ikotec 3000?



The vehicle is shown by the force  $F$  representing its weight. The force  $F$  will remain vertical as the vehicle gradually inclines. On the other side is the point of rotation  $R$ . While the vehicle is inclining, the distance  $d$  between  $F$  and  $R$  decreases. Until this distance  $d$  doesn't reach zero or turn negative, the vehicle **WILL NOT TURN OVER.**

*This will never happen with the Ikotec 3000*